

Egyenes hidraulika forgócsatlakozók BSP colos menettel

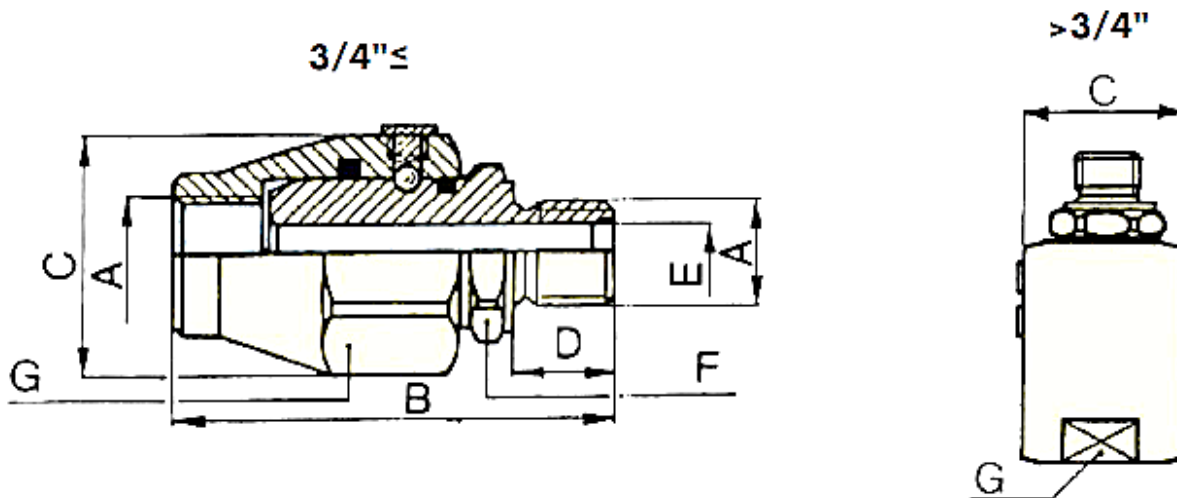

Műszaki paraméterek:

Cikkszám	Menet (A)	B [mm]	C [mm]	D [mm]	E [mm]	F [mm]	G [mm]	Max. nyomás (forgás közben) [bar]	Max. nyomás [bar]
FCSE-1/4	1/4" - 19	61	33	11	6,5	19	30	200	400
FCSE-3/8	3/8" - 19	66	37	14	9	24	34	200	400
FCSE-1/2	1/2" - 14	70	42	15	12	27	36	150	300
FCSE-3/4	3/4" - 14	79	50	19	16	34	45	150	300
FCSE-1	1" - 11	90	55	21	20	41	50	100	300
FCSE-1 1/4	1 1/4" - 11	101	60	24	28	50	55	100	300
FCSE-1 1/2	1 1/2" - 11	110	70	25	34	55	65	80	300
FCSE-2	2" - 11	118	85	27	44	65	75	50	250

90° - os hidraulika forgócsatlakozók BSP colos menettel

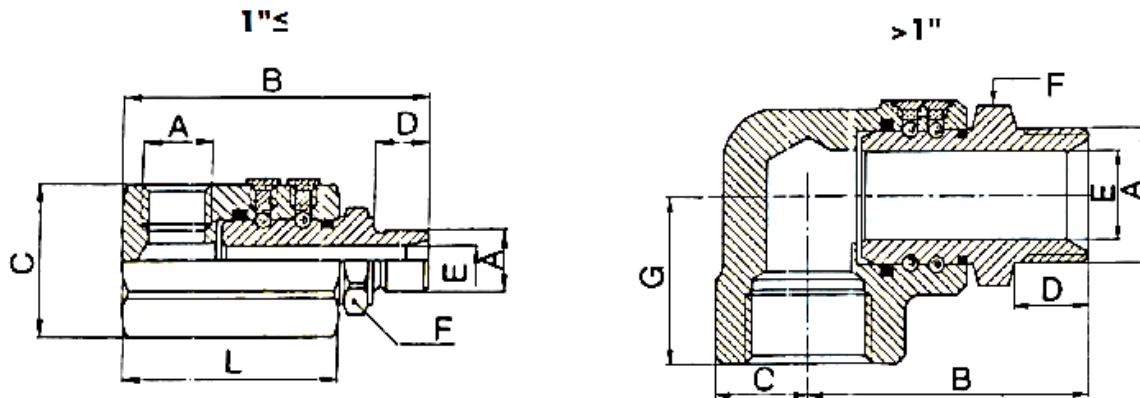

Műszaki paraméterek:

Cikkszám	Menet (A)	B [mm]	C [mm]	D [mm]	E [mm]	F [mm]	G [mm]	Max. nyomás (forgás közben) [bar]	Max. nyomás [bar]
FCS90-1/4	1/4" - 19	69	30,5	11	6,5	19	58	200	400
FCS90-3/8	3/8" - 19	78	41,5	14	9	24	63	200	400
FCS90-1/2	1/2" - 14	86	44	15	12	27	68,5	150	300
FCS90-3/4	3/4" - 14	99	58	19	16	34	79	150	300
FCS90-1	1" - 11	113	60	21	20	41	90	100	300
FCS90-1 1/4	1 1/4" - 11	92	31,5	24	28	50	56,5	100	300
FCS90-1 1/2	1 1/2" - 11	104	38	25	34	55	62	80	300
FCS90-2	2" - 11	111	45	27	44	65	67	50	250